

Constraint Propagation and Consistency Enforcement

Jorge Cruz

DI/FCT/UNL

Nov 2018

Constraint Propagation and Consistency Enforcement

Constraint Propagation

Narrowing Functions and their Properties

Fixed-Points of Narrowing Functions

Contraction Obtained by Applying a Narrowing Function

Constraint Propagation Algorithm and its Properties

Consistency Enforcement

Arc-Consistency and Interval-Consistency

Hull-Consistency

Box-Consistency

Local Consistency and Higher Order Consistencies

Constraint Propagation

The propagation process is a successive reduction of variables domains by successive application of narrowing functions associated with the constraints of the CCSP

Narrowing Functions and their Properties

The properties of the propagation algorithm are derived from the properties of the narrowing functions used for pruning the domains

A narrowing function must be able to narrow the domains (contractance) without losing solutions (correctness)

Narrowing Function. Let $P=(X,D,C)$ be a CCSP. A narrowing function NF associated with a constraint $c=(s,\rho)$ (with $c \in C$) is a mapping between elements of 2^D with the following properties (where A is any element of the domain of NF):

P1) $NF(A) \subseteq A$ (contractance)

P2) $\forall d \in A \ d \notin NF(A) \Rightarrow d[s] \notin \rho$ (correctness) □

Constraint Propagation

Narrowing Functions and their Properties

Monotonicity and *Idempotency* are additional properties common to most of the narrowing functions used in interval constraints

Monotonicity and Idempotency. Let $P=(X,D,C)$ be a CCSP. Let NF be a narrowing function associated with a constraint of C . Let A_1 and A_2 be any elements of the domain of NF . NF is respectively monotonic and idempotent iff the following properties hold:

P3) $A_1 \subseteq A_2 \Rightarrow NF(A_1) \subseteq NF(A_2)$ (monotonicity)

P4) $NF(NF(A_1)) = NF(A_1)$ (idempotency) □

Constraint Propagation

Fixed-Points of Narrowing Functions

An important concept related with the narrowing functions is the notion of a fixed point

Fixed-Points. Let $P=(X,D,C)$ be a CCSP. Let NF be a narrowing function associated with a constraint of C . Let A be an element of Domain_{NF} . A is a fixed-point of NF iff:

$$NF(A) = A.$$

The set of all fixed-points of NF within A , denoted $\text{Fixed-Points}_{NF}(A)$, is the set:

$$\text{Fixed-Points}_{NF}(A) = \{ A_i \in \text{Domain}_{NF} \mid A_i \subseteq A \wedge NF(A_i) = A_i \}$$



The union of all fixed-points of a monotonic narrowing function within A is a fixed-point which is the greatest fixed-point within A

Union of Fixed-Points. Let $P=(X,D,C)$ be a CCSP. Let NF be a monotonic narrowing function associated with a constraint of C , and A an element of its domain. The union of all fixed-points of NF within A is the greatest fixed-point of NF in A :

$$\cup \text{Fixed-Points}_{NF}(A) \in \text{Fixed-Points}_{NF}(A)$$

$$\forall A_i \in \text{Fixed-Points}_{NF}(A) \quad A_i \subseteq \cup \text{Fixed-Points}_{NF}(A)$$



Constraint Propagation

Contraction Obtained by Applying a Narrowing Function

The contraction resulting from applying a monotonic narrowing function to A is limited by the greatest fixed-point within A :

No value combination included in the greatest fixed-point may be discarded in the contraction

If the monotonic narrowing function is idempotent, the result of the contraction is precisely the greatest fixed-point within A

Contraction Applying a Narrowing Function. Let $P=(X,D,C)$ be a CCSP. Let NF be a monotonic narrowing function associated with a constraint of C and A an element of its domain. The greatest fixed-point of NF within A is included in the element obtained by applying NF to A :

$$\cup \text{Fixed-Points}_{NF}(A) \subseteq NF(A)$$

In particular, if NF is also idempotent then:

$$\cup \text{Fixed-Points}_{NF}(A) = NF(A)$$



Constraint Propagation

Constraint Propagation Algorithm and its Properties

The propagation algorithm applies successively each narrowing function until a fixed-point is attained:

```
function prune(a set  $Q$  of narrowing functions, an element  $A$  of the domains lattice)
(1)    $S \leftarrow \emptyset$  ;
(2)   while  $Q \neq \emptyset$  do
(3)     choose  $NF \in Q$ ;
(4)      $A' \leftarrow NF(A)$  ;
(5)     if  $A' = \emptyset$  then return  $\emptyset$  ;
(6)      $P \leftarrow \{ NF' \in S : \exists x \in \text{Relevant}_{NF'} A[x] \neq A'[x] \}$  ;
(7)      $Q \leftarrow Q \cup P ; S \leftarrow S \setminus P$  ;
(8)     if  $A' = A$  then  $Q \leftarrow Q \setminus \{NF\}$  ;  $S \leftarrow S \cup \{NF\}$  end if;
(9)      $A \leftarrow A'$  ;
(10)  end while
(11)  return  $A$  ;
end function
```

The algorithm is an adaptation of the original propagation algorithm AC3 used for solving CSPs with finite domains

Constraint Propagation

Constraint Propagation Algorithm and its Properties

From the properties of the narrowing functions it is possible to prove that the propagation algorithm terminates and is correct

If all the narrowing functions are monotonic then it is confluent (the result is independent from the selection criteria) and computes the greatest common fixed-point included in the initial domains

Properties of the Propagation Algorithm. Let $P=(X,D,C)$ be a CCSP. Let set S_0 be a set of narrowing functions (obtained from the set of constraints C). Let A_0 be an element of $\text{Domain}_{\text{NF}}$ (where $NF \in S_0$) and d an element of D ($d \in D$). The propagation algorithm $\text{prune}(S_0, A_0)$ terminates and is correct:

$$\forall d \in A_0 \ d \text{ is a solution of the CCSP} \Rightarrow d \in \text{prune}(S_0, A_0)$$

If S_0 is a set of monotonic narrowing functions then the propagation algorithm is confluent and computes the greatest common fixed-point included in A_0 . \square

The selection criterion is irrelevant for the pruning obtained but it may be very important for the efficiency of the propagation

Consistency Enforcement

The fixed-points of the narrowing functions associated with a constraint characterize a local property enforced on its variables

Such property is called local consistency:

- depends only on the narrowing functions associated with one constraint (local)
- defines the value combinations that are not pruned by them (consistent)

Local consistency is a partial consistency:

- imposing it on a CCSP is not sufficient to remove all inconsistent value combinations among its variables

Stronger higher order consistency requirements may then be imposed establishing global properties over the variable domains

Consistency Enforcement

Local consistencies used for solving CCSPs are approximations of arc-consistency, developed for solving CSPs with finite domains

Arc-Consistency and Interval-Consistency

A constraint is said to be arc-consistent wrt a set of value combinations iff, within this set, for each value of each variable there is a value combination that satisfy the constraint:

Arc-Consistency. Let $P=(X,D,C)$ be a CSP. Let $c=(s,\rho)$ be a constraint of the CSP. Let A be an element of the power set of D ($A \in 2^D$). The constraint c is arc-consistent wrt A iff:

$$\forall x_i \in S \quad \forall d_i \in A[x_i] \quad \exists d \in A[s] \quad (d[x_i]=d_i \wedge d \in \rho)$$

which, is equivalent to:

$$\forall x_i \in S \quad A[x_i] = \{ d[x_i] \mid d \in \rho \cap A[s] \} = \pi_{x_i}^{\rho}(A[s])$$



Consistency Enforcement

Example

$$P = (X, D, C) = (\langle x_1, x_2 \rangle, D_1 \times D_2, \{c\})$$

$$c \equiv x_1 \times (x_2 - x_1) = 0$$

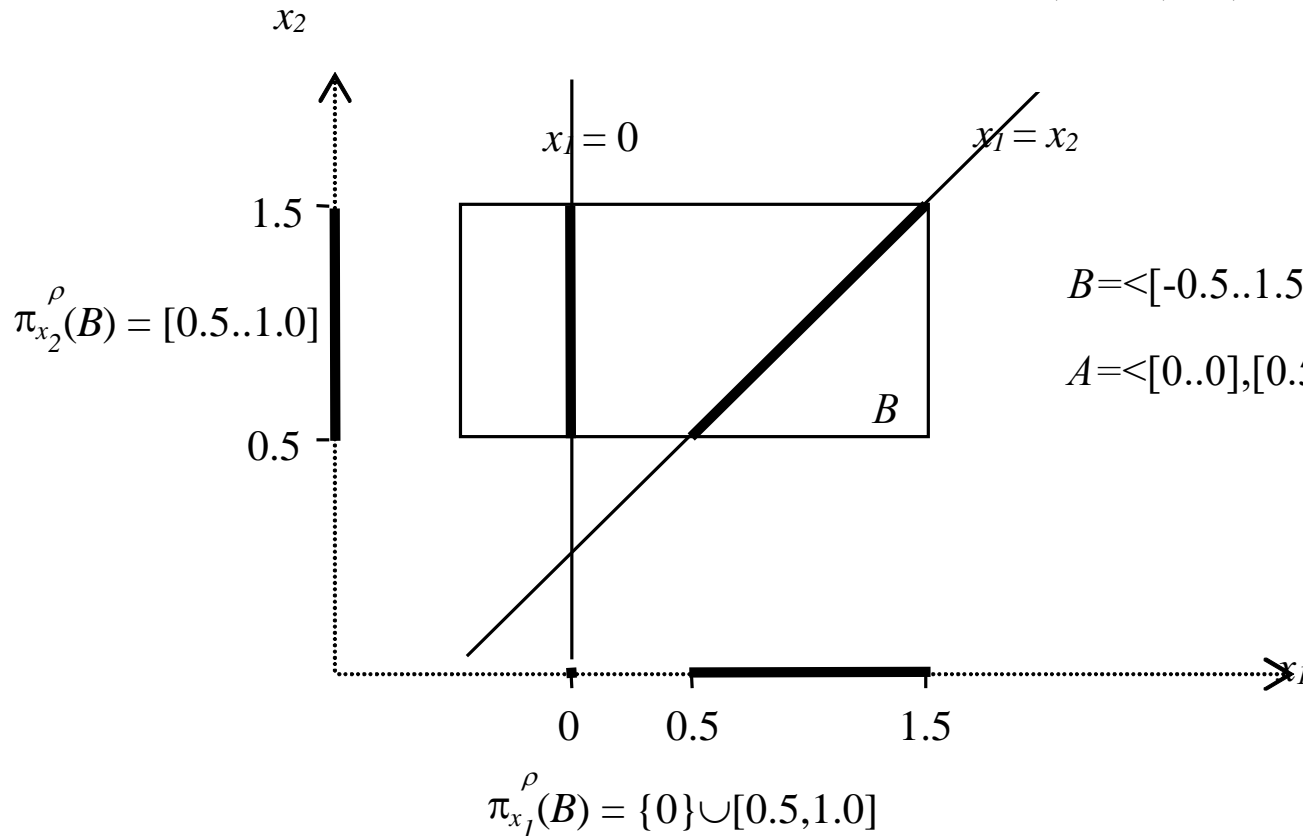

B is not arc-consistent (ex: if $x_1=0.25$ there is no value for x_2 to satisfy c)

A is arc-consistent ($\pi_{x_1}^\rho(A) = A[x_1]$ and $\pi_{x_2}^\rho(A) = A[x_2]$)

Consistency Enforcement

Arc-Consistency and Interval-Consistency

In continuous domains, arc-consistency cannot be obtained in general due to machine limitations for representing real numbers

The best approximation of arc-consistency wrt a set of real valued combinations is the set approximation of each variable domain

A constraint is interval-consistent wrt a set of value combinations iff for each canonical F -interval representing a variable sub-domain there is a value combination satisfying the constraint

Interval-Consistency. Let $P=(X,D,C)$ be a CCSP. Let $c=(s,\rho)$ be a constraint of the CCSP ($c \in C$). Let A be an element of the power set of D ($A \in 2^D$). The constraint c is interval-consistent wrt A iff:

$$\forall x_i \in S \quad \forall [a..a^+] \subseteq A[x_i] \quad \exists d \in A[s] \quad (d[x_i] \in (a..a^+) \wedge d \in \rho) \wedge \\ \forall [a] \subseteq A[x_i] \quad \exists d \in A[s] \quad (d[x_i] \in (a^-..a^+) \wedge d \in \rho) \quad (\text{where } a \text{ is an } F\text{-number})$$

which is equivalent to:

$$\forall x_i \in S \quad A[x_i] = S_{\text{apx}}(\{ d[x_i] \mid d \in \rho \cap A[s] \}) = S_{\text{apx}}(\pi_{x_i}^{\rho}(A[s])) \quad \square$$

Consistency Enforcement

Example

$$P = (X, D, C) = (\langle x_1, x_2 \rangle, D_1 \times D_2, \{c\})$$

$$c \equiv x_1 \times (x_2 - x_1) = 0$$

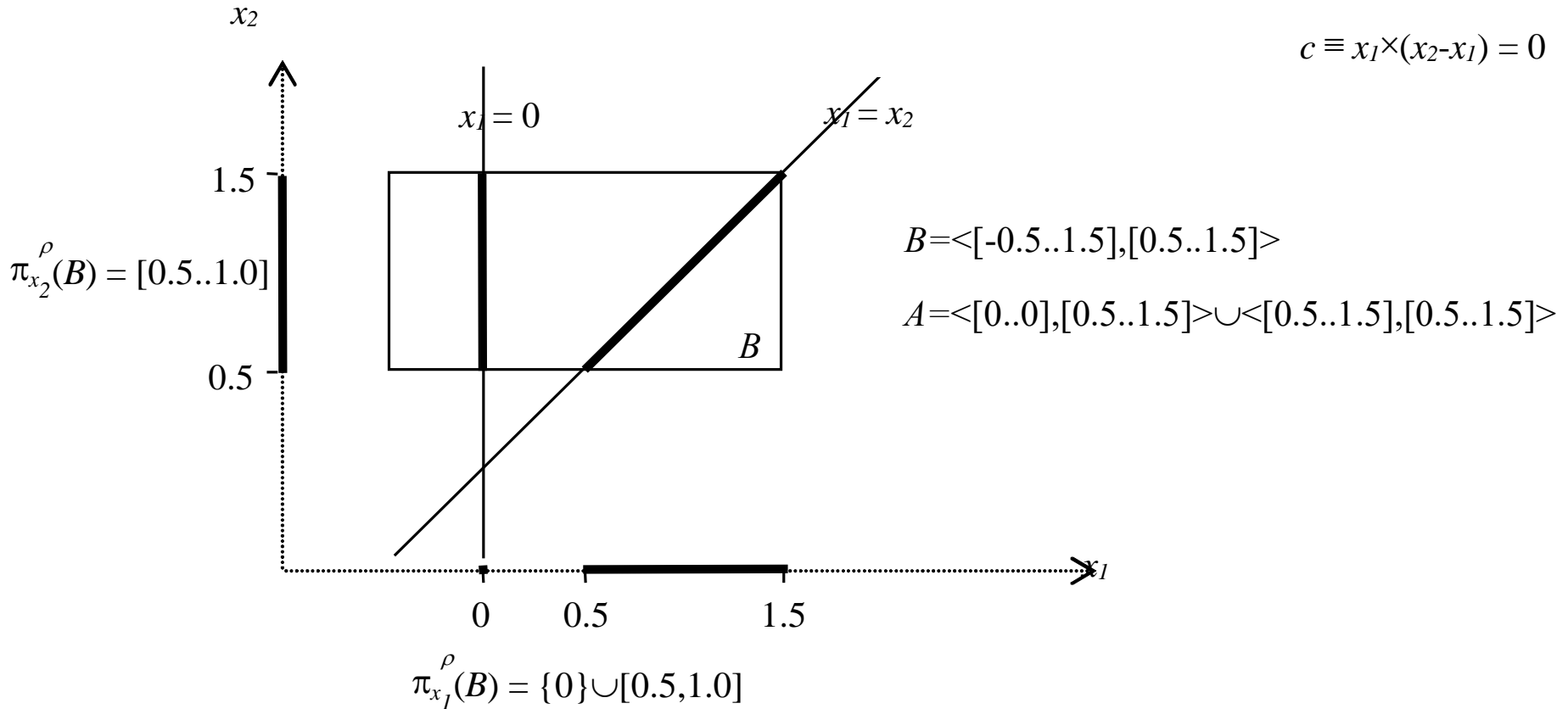

B is not interval-consistent (if $x_1 \in [0.250, 0.251]$ there is no x_2 satisfying c)

A is interval-consistent ($S_{apx}(\pi_{x_1}^\rho(A)) = A[x_1]$ and $S_{apx}(\pi_{x_2}^\rho(A)) = A[x_2]$)

Consistency Enforcement

Arc-Consistency and Interval-Consistency

Interval-consistency can only be enforced on primitive constraints where the set approximation of the projection function can be obtained using extended interval arithmetic

Structures (not F -intervals) must be considered for representing each variable domain as a non-compact set of real values

In practice, the enforcement of interval-consistency can be applied only to small problems:

- the number of non-contiguous F -intervals may grow exponentially, requiring an unreasonably number of computations for each narrowing function.

The approximations of arc-consistency most widely used in continuous domains assume the convexity of the variable domains, in order to represent them by single F -intervals

Consistency Enforcement

Hull-Consistency

Hull-consistency (or 2B-consistency) requires the satisfaction of the arc-consistency property only at the bounds of the F -intervals that represent the variable domains

A constraint is said to be hull-consistent wrt an F -box iff, for each bound of the F -interval representing the domain of a variable there is a value combination satisfying the constraint:

Hull-Consistency. Let $P=(X,D,C)$ be a CCSP. Let $c=(s,\rho)$ be a constraint of the CCSP ($c \in C$). Let B be an F -box which is an element of the power set of D ($B \in 2^D$). The constraint c is hull-consistent wrt B iff:

$$\forall x_i \in s \quad \exists d_l \in B[s] \quad (d_l[x_i] \in [a..a^+] \wedge d_l \in \rho) \quad \wedge$$
$$\exists d_r \in B[s] \quad (d_r[x_i] \in [b^-..b] \wedge d_r \in \rho) \quad \text{(where } B[x_i]=[a..b])$$

which is equivalent to:

$$\forall x_i \in s \quad B[x_i] = I_{hull}(\{ d[x_i] \mid d \in \rho \cap B[s] \}) = I_{hull}(\pi_{x_i}^\rho(B[s])) \quad \square$$

Consistency Enforcement

Example

$$P = (X, D, C) = (\langle x_1, x_2 \rangle, D_1 \times D_2, \{c\})$$

$$c \equiv x_1 \times (x_2 - x_1) = 0$$

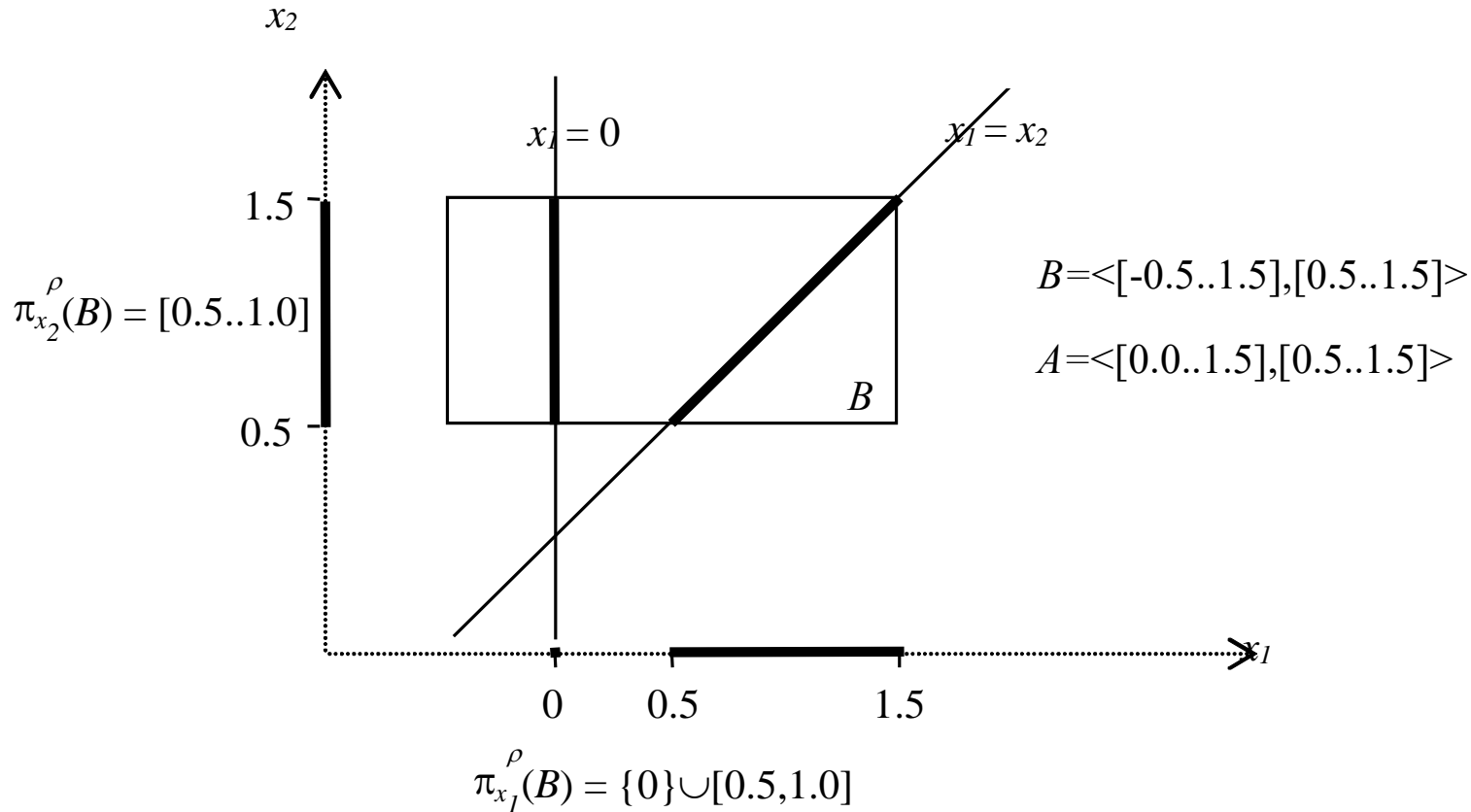

B is not hull-consistent (if $x_1 \in [-0.5, -0.499]$ there is no x_2 satisfying c)

A is hull-consistent ($I_{hull}(\pi_{x_1}^\rho(A)) = A[x_1]$ and $I_{hull}(\pi_{x_2}^\rho(A)) = A[x_2]$)

Consistency Enforcement

Hull-Consistency

Hull-consistency can only be enforced on primitive constraints where the hull approximation of the projection function can be obtained using extended interval arithmetic and union hull operations to avoid multiple disjoint F -intervals

The major drawback of any decomposition approach is the worsening of the dependency problem:

the satisfaction of a local property on each constraint does not imply the existence of value combinations satisfying simultaneously all of them

Hull-consistency enforcement is particularly ineffective if the original constraints contain multiple occurrences of variables

Consistency Enforcement

Box-Consistency

The drawbacks of the decomposition approach motivated the constraint Newton method, which can be applied directly to complex constraints

A constraint is said to be box-consistent wrt an F -box iff, for each bound of the F -interval representing the domain of a variable there is a box (bound+other F -intervals) that satisfies the interval projection condition:

Box-Consistency. Let $P=(X,D,C)$ be a CCSP. Let $c=(s,\rho)$ be a constraint of the CCSP ($c \in C$) expressed in the form $e_c \diamond 0$ (with $\diamond \in \{\leq, =, \geq\}$ and e_c a real expression). Let F_E be an interval expression representing an interval extension F of the real function represented by e_c . Let B be an F -box which is an element of the power set of D ($B \in 2^D$). c is box-consistent wrt B and F_E iff:

$$\forall x_i \in S \exists r_1 \in F_E(B_1) r_1 \diamond 0 \wedge \exists r_2 \in F_E(B_2) r_2 \diamond 0$$

where B_1 and B_2 are two F -boxes such as:

$$B_1[x_i] = \text{cleft}(B[x_i]), B_2[x_i] = \text{cright}(B[x_i]) \text{ and } \forall x_j \in S (x_j \neq x_i \Rightarrow B_1[x_j] = B_2[x_j] = B[x_j]). \quad \square$$

Consistency Enforcement

Example

$$P = (X, D, C) = (\langle x_1, x_2 \rangle, D_1 \times D_2, \{c\})$$

$$c \equiv x_1 \times (x_2 - x_1) = 0$$

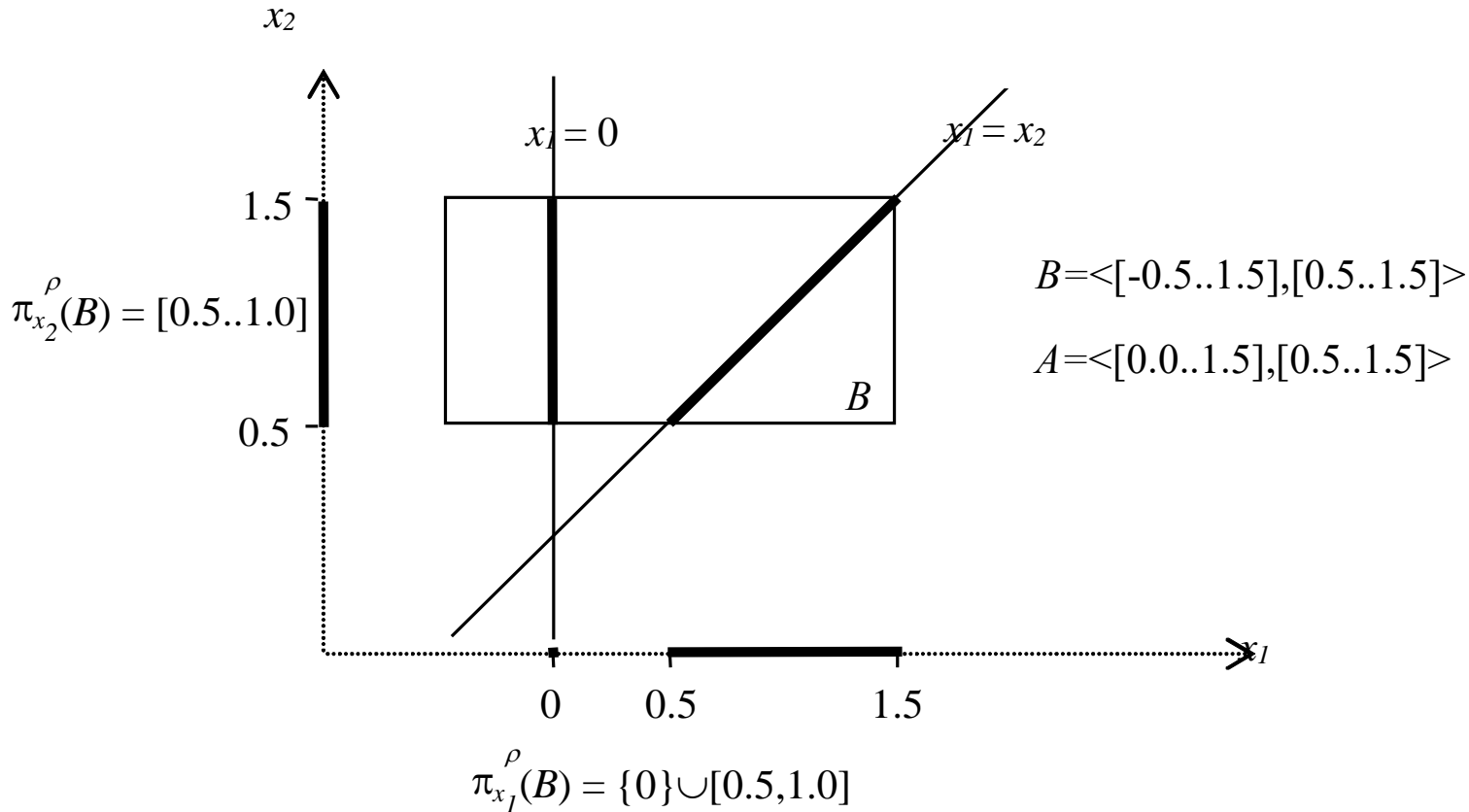

B is not box-consistent ($0 \notin [-0.5, -0.499] \times ([0.5, 1.5] - [-0.5, -0.499]) = [-1, -0.498]$)

A is box-consistent:

$$0 \in [0..0.001] \times ([0.5..1.5] - [0..0.001]) \quad \text{and} \quad 0 \in [1.499..1.5] \times ([0.5..1.5] - [1.499..1.5])$$

$$0 \in [0..1.5] \times ([0.5..0.501] - [0..1.5]) \quad \text{and} \quad 0 \in [0..1.5] \times ([1.499..1.5] - [0..1.5])$$

Consistency Enforcement

Box-Consistency

Although box-consistency is weaker than hull-consistency for the same constraint, the enforcement of box-consistency may achieve better pruning since it may be directly applied to complex constraints

For primitive constraints box-consistency and hull-consistency are equivalent (with infinite precision)

For complex constraints box-consistency is stronger than hull-consistency applied on the primitive constraints obtained by decomposition

Consistency Enforcement

Local Consistency and Higher Order Consistencies

Generalising the concept of local consistency from a constraint to the set of constraints:

a CCSP is locally consistent (interval, hull or box-consistent) wrt a set A of real valued combinations iff all its constraints are locally consistent wrt A

Since the propagation algorithm obtains the greatest common fixed-point (of the monotonic narrowing functions) included in the original domains, then applying it to a set A results in the largest subset $A' \subseteq A$ for which each constraint is locally consistent.

Local-Consistency. Let $P=(X,D,C)$ be a CCSP. Let A be an element of the power set of D ($A \in 2^D$). P is locally-consistent wrt A iff:

$\forall c \in C$ c is locally-consistent wrt A

Let S be a set of monotonic narrowing functions associated with the constraints in C which enforce a particular local consistency by constraint propagation:

P is locally-consistent wrt $\text{prune}(S,A)$

$\forall A' \subseteq A$ (P is locally-consistent wrt $A' \Rightarrow A' \subseteq \text{prune}(S,A)$)



Consistency Enforcement

Local Consistency and Higher Order Consistencies

When only local consistency techniques are applied to non-trivial problems the achieved reduction of the search space is often poor

$$c_1 \equiv x_1^2 + x_2^2 - 2^2 \leq 0$$

$$c_2 \equiv (x_1 - 1)^2 + (x_2 - 1)^2 - 2.5^2 \geq 0.$$

Box obtained by enforcing a local consistency on the initial box

Smallest box enclosing all solutions within the initial box

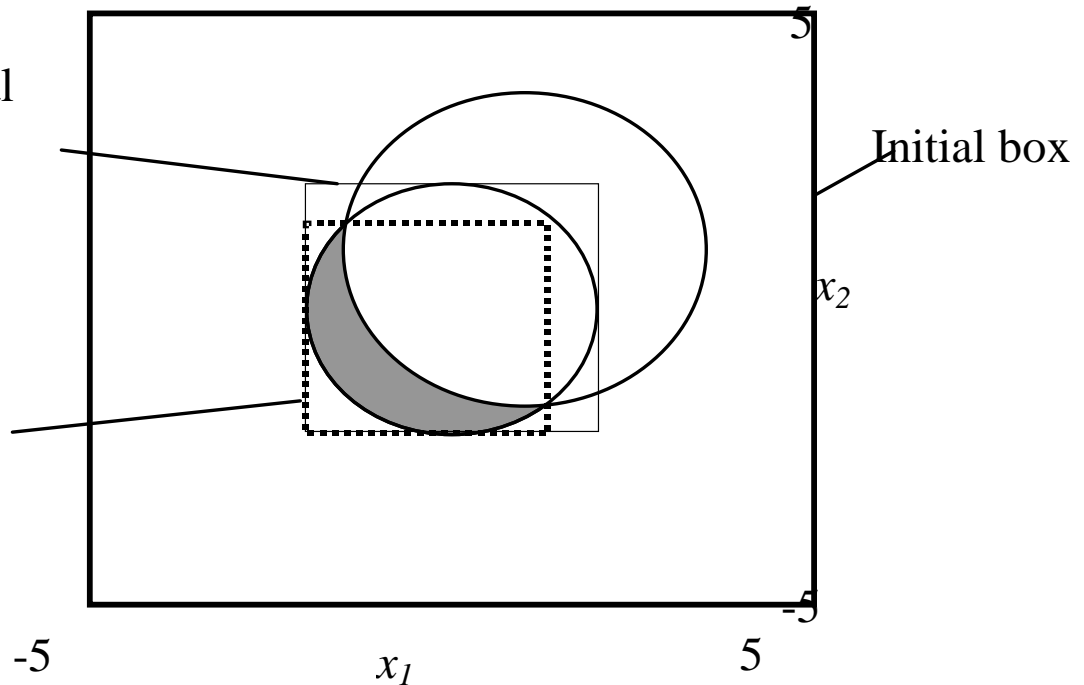

Consistency Enforcement

Local Consistency and Higher Order Consistencies

Better pruning of the variable domains may be achieved if, complementary to a local property, some (global) properties are also enforced on the overall constraint set

Higher order consistency types used in continuous domains are approximations of strong k -consistency (with $k > 2$) restricted to the bounds of the variable domains:

A CSP is k -consistent ($k \geq 2$) iff any consistent instantiation of $k-1$ variables can be extended by instantiating any of the remaining variables.

A CSP is strongly k -consistent if it is i -consistent for all $i \leq k$.

Strong 2-consistency corresponds to arc-consistency and hull-consistency is an approximation of strong 2-consistency restricted to the bounds of the variable domains

Consistency Enforcement

Local Consistency and Higher Order Consistencies

3B-consistency and Bound-consistency, are generalisations of hull and box-consistency respectively:

if the domain of one variable is reduced to one of its bounds then the obtained F -box must contain a sub-box for which the CCSP is locally consistent.

The following is a generic definition for the consistency types used in continuous domains (local consistency is just a special case with $k=2$):

k B-Consistency. Let $P=(X,D,C)$ be a CCSP. Let A be an element of the power set of D ($A \in 2^D$) and k an integer number.

P is 2B-Consistent wrt A iff P is locally-consistent wrt A

$\forall k > 2$ P is k B-Consistent wrt A iff

$\forall x_i \in X$ ($\exists A_1 \subseteq B_1$ P is $(k-1)$ B-Consistent wrt A_1 \wedge $\exists A_2 \subseteq B_2$ P is $(k-1)$ B-Consistent wrt A_2)

where B_1 and B_2 are two elements of the power set of D such that:

$B_1[x_i] = \text{cleft}(B[x_i])$, $B_2[x_i] = \text{cright}(B[x_i])$ and $\forall x_j \in X$ ($x_j \neq x_i \Rightarrow B_1[x_j] = B_2[x_j] = B[x_j]$). □

Consistency Enforcement

Local Consistency and Higher Order Consistencies

The algorithms to enforce higher order consistencies interleave constraint propagation with search techniques

The growth in computational cost of the enforcing algorithm limits the practical applicability of such criteria

Consistency Enforcement

Local Consistency and Higher Order Consistencies

All the consistency criteria used in continuous domains, either local or higher order consistencies, are partial consistencies

The adequacy of a partial consistency for a particular CCSP must be evaluated taking into account the trade-off between the pruning it achieves and its execution time

It is necessary to be aware that the filtering process is performed within a larger procedure for solving the CCSP and it may be globally advantageous to obtain faster, if less accurate, results